

Redundant Systems (Transmit Only)

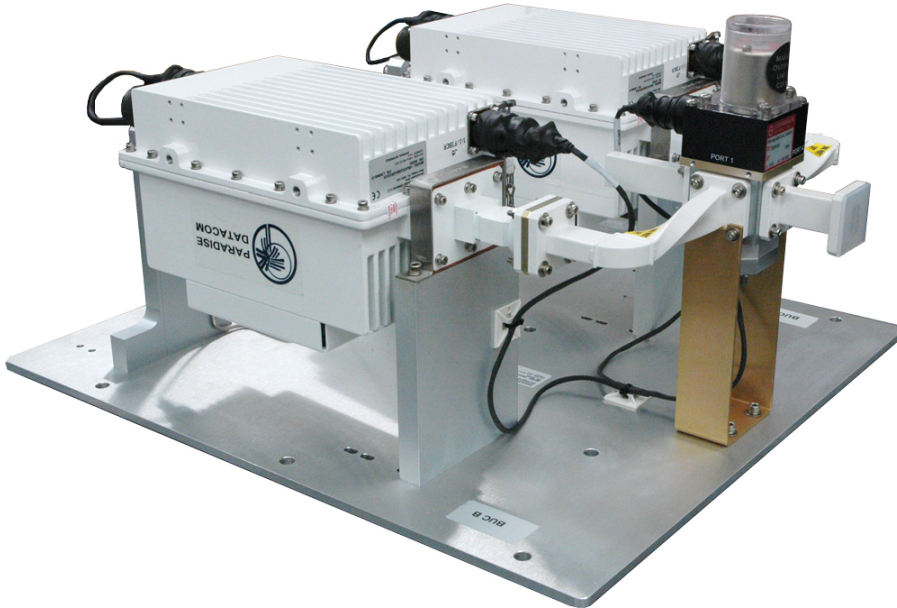

1:1 Redundant 25W Ku-Band Plate Assembly

Description

The Teledyne Paradise Datacom family of lightweight vBUCs can be configured in a variety of custom systems to meet any redundant system application.

Redundant systems are available in the following output power levels:

25W, 50W, 80W	C-Band
10W, 25W, 35W, 80W	X-Band
10W, 16W, 25W, 40W	Ku-Band

The vBUC is also available in 1:2 redundant configurations with the addition of a RCP2-1200 Redundant System Controller. Chain 1:1 redundancy is available with the use of a RCPD-1100 Dual Redundant Controller.

FEATURES

- Single box BUC output power levels to:
 - 80W C-Band
 - 80W X-Band
 - 40W Ku-Band
- Wide Range of Interface Capability including:
 - FSK Control
 - RS 485
 - Ethernet
- Output Power Detection
- Adjustable Gain
- Automatic detection of external reference power and frequency
- Multiple external reference frequency operation including:
 - 5, 10, 20, 25 & 50 MHz

OPTIONS

- 6 Amp External Bias Tee for IFL Bias feed
- High Stability internal 10 MHz reference
- AC Power Supply
- 24 VDC operation on selected models
- TX & RX Reject Filters
- Extended Bands
- LNB Power & Reference Port

SPECIFICATIONS

- 1:1 Plate dimension:
 - 18 x 20 x 11.0 inches
 - 457 x 508 x 279 mm
 - (w/o AC Power Supplies)
- 1:1 Plate weight:
 - 36.0 lbs. / 16.4 kg.
 - (w/o AC Power Supplies)

Redundant Systems (Transmit Only)

Due to signal losses inherent in redundant system configurations, the output powers and gain levels are slightly reduced compared with a single unit's specifications. The following tables show the typical system output powers and gain levels for Teledyne Paradise Datacom redundant vBUC systems.

C-Band Redundant System Output Power Levels

PARAMETER	MODEL NUMBER	NOTES	LIMITS	UNITS
Frequency Range		*	5.850 to 6.425	GHz
Output Power @: Saturation/ P_{1dB} (Guaranteed minimum)	VBUC25AAXXXXX VBUC50AAXXXXX	<u>Gain</u> 69 dB 72 dB	P_{sat} / P_{1dB} 44.25/43.75 (26.6/23.7) 47.25/46.75 (53.1/47.3)	dBm (W) dBm (W)
Power Requirements 48 VDC Input @ max current draw per unit	VBUC25AAXXXXX VBUC50AAXXXXX	<u>24 VDC current</u> 7.2 12.0	<u>48 VDC current</u> 3.6 5.8	Amps Amps

* Available with Extended band frequencies; De-rate output power linearly by 1 dB over 6.425 - 6.725 GHz.
For full vBUC specifications, see the vBUC Specification Sheet, Drawing Number 208795.

80W C-Band Redundant System Output Power Levels

PARAMETER	MODEL NUMBER	NOTES	LIMITS	UNITS
Frequency Range		*	5.850 to 6.425	GHz
Output Power @: Saturation (Guaranteed minimum)	VBUC80AAXXWXX	<u>Gain</u> 74 dB	P_{sat} 48.75 (75)	dBm (W)
Power Requirements Input Power @ max current draw per unit	VBUC80AAXXWXX	<u>24 VDC current</u> N/A	<u>48 VDC Current</u> 7.9	Amps

* Available with Extended band frequencies; De-rate output power linearly by 1 dB over 6.425 - 6.725 GHz.
For full vBUC specifications, see the GaN vBUC Specification Sheet, Drawing Number 208796.

X-Band Redundant System Output Power Levels

PARAMETER	MODEL NUMBER	NOTES	LIMITS	UNITS
Frequency Range			7.90 to 8.40	GHz
Output Power @: Saturation/ P_{1dB} (Guaranteed minimum)	VBUCX10AAXXXXX VBUCX25AAXXXXX VBUCX35AAXXXXX	<u>Gain</u> 65 dB 69 dB 70 dB	P_{sat} / P_{1dB} 40.25/39.75 (10.6/9.4) 44.25/43.75 (26.6/23.7) 45.25/44.75 (33.5/29.9)	dBm (W) dBm (W) dBm (W)
Power Requirements 48 VDC Input @ max current draw per unit	VBUCX10AAXXXXX VBUCX25AAXXXXX VBUCX35AAXXXXX	<u>24 VDC current</u> 4.2 9.6 11.0	<u>48 VDC Current</u> 2.0 4.7 5.2	Amps Amps Amps

For full vBUC specifications, see the vBUC Specification Sheet, Drawing Number 208795.

80W X-Band Redundant System Output Power Levels

PARAMETER	MODEL NUMBER	NOTES	LIMITS	UNITS
Frequency Range			7.90 to 8.40	GHz
Output Power @: Saturation (Guaranteed minimum)	VBUCX80AAXXWXX	<u>Gain</u> 74 dB	P_{sat} 48.75 (75)	dBm (W)
Power Requirements Input Power @ max current draw per unit	VBUCX80AAXXWXX	<u>24 VDC current</u> N/A	<u>48 VDC Current</u> 7.9	Amps

For full vBUC specifications, see the GaN vBUC Specification Sheet, Drawing Number 208796.

Redundant Systems (Transmit Only)

10W - 25W Ku-Band Redundant System Output Power Levels

PARAMETER	MODEL NUMBER	NOTES	LIMITS	UNITS
Frequency Range		*	14.0 to 14.5	GHz
Output Power @: Saturation/ P_{1dB} (Guaranteed minimum)	VBUCK10AAXXXXX VBUCK16AAXXXXX VBUCK25AAXXXXX	Gain 65 dB 67 dB 68 dB	P_{sat} / P_{1dB} 40.25/39.75 (10.6/9.4) 42.75/41.75 (18.8/15.0) 43.75/42.75 (23.7/18.8)	dBm (W) dBm (W) dBm (W)
Power Requirements 48 VDC Input @ max current draw per unit	VBUCK10AAXXXXX VBUCK16AAXXXXX VBUCK25AAXXXXX	24 VDC current 6.2 9.1 10.1	48 VDC Current 3.0 4.5 5.0	Amps Amps Amps

* Available with Extended band frequencies; De-rate output power linearly by 1 dB over 13.75 - 14.0 GHz.
For full vBUC specifications, see the vBUC Specification Sheet, Drawing Number 208795.

40W Ku-Band Redundant System Output Power Levels

PARAMETER	MODEL NUMBER	NOTES	LIMITS	UNITS
Frequency Range		*	14.0 to 14.5	GHz
Output Power @: Saturation (Guaranteed minimum)	VBUCK40AAXXWXX	Gain 71 dB	P_{sat} 45.75 (38)	dBm (W)
Power Requirements Input Power @ max current draw per unit	VBUCK40AAXXWXX	24 VDC current N/A	48 VDC Current 6.0	Amps

* Available with Extended band frequencies; De-rate output power linearly by 1 dB over 13.75 - 14.0 GHz.
For full vBUC specifications, see the GaN vBUC Specification Sheet, Drawing Number 208796.

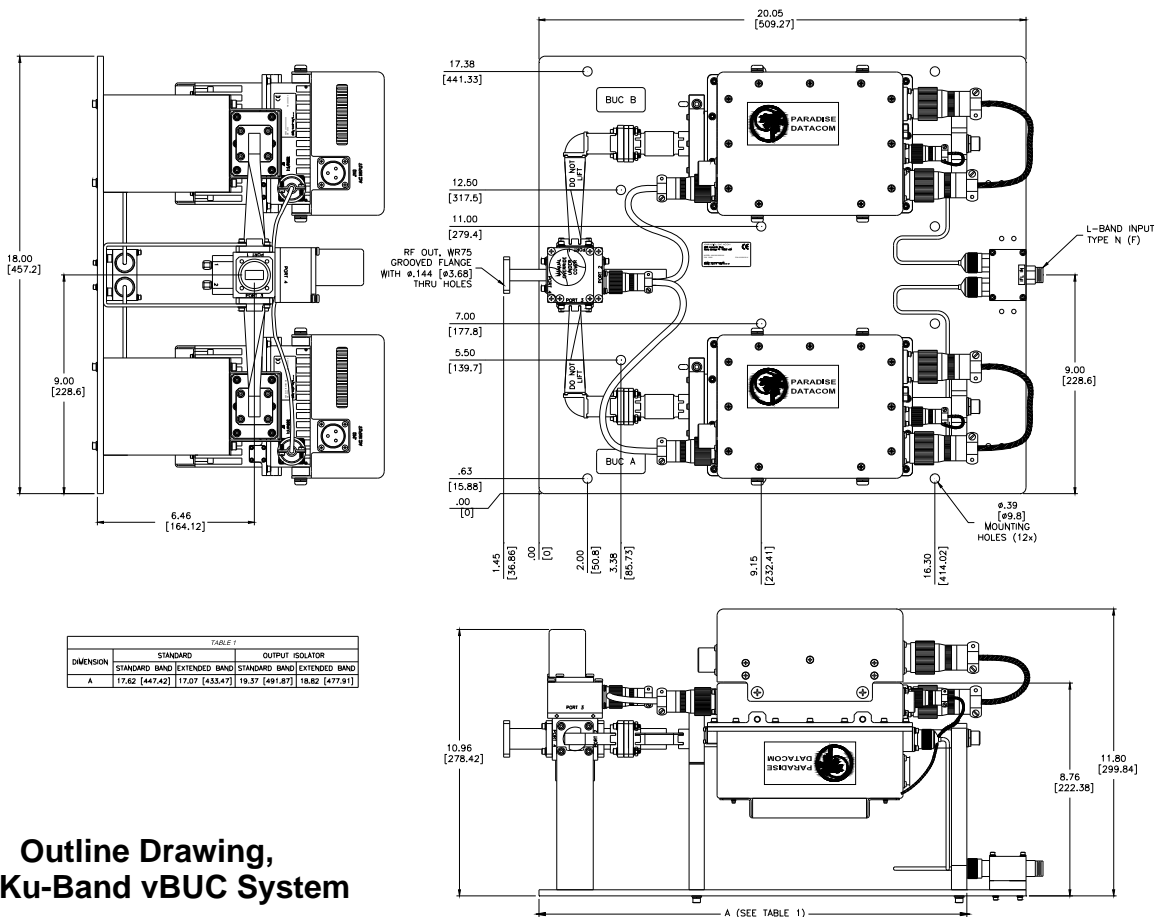

**Outline Drawing,
1:1 Ku-Band vBUC System**

1:1 Redundant Systems (Transmit Only)

1:1 systems with input switching require the internal reference option in each vBUC.

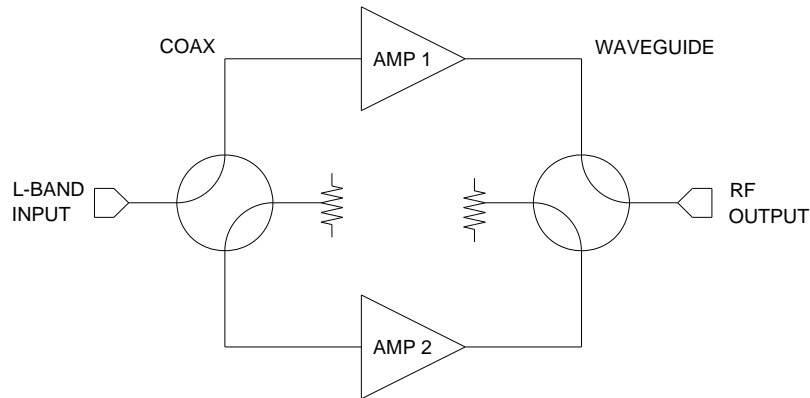

Block Diagram, 1:1 redundant system, input switching

1:1 systems with input splitting can use an external reference. Units can be fitted with an internal reference for auto-detection and switch to an external reference at need.

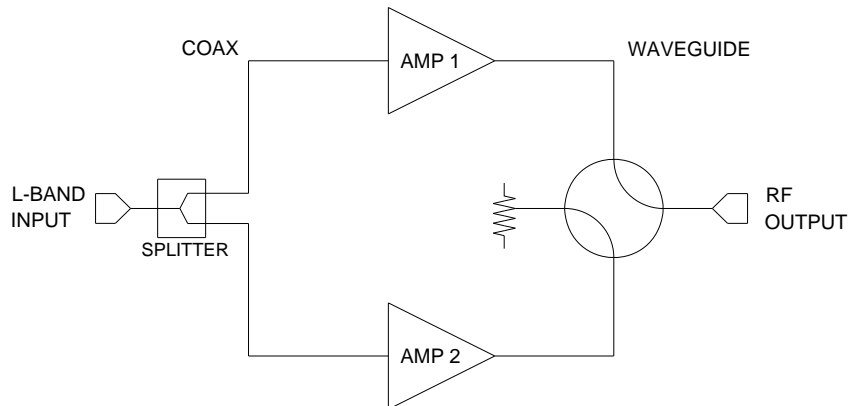

Block Diagram, 1:1 redundant system, input splitting

1:1 Chain Redundant Systems require a RCPD-1100 Dual Redundant System Controller.

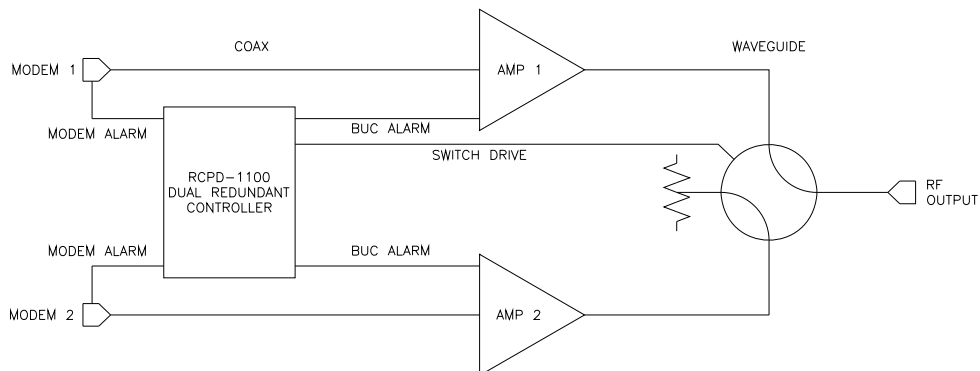

Block Diagram, 1:1 chain redundant system

1:2 Redundant Systems (Transmit Only)

1:2 Redundant Systems require the use of a RCP2-1200 Redundant System Controller.

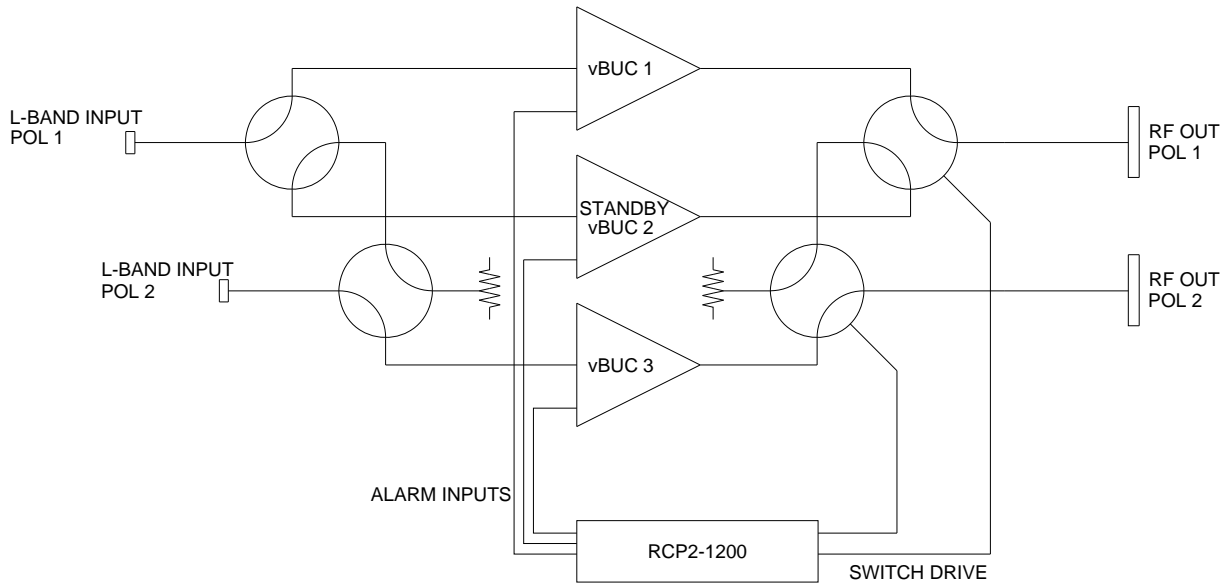

Block Diagram, 1:2 Redundant System, Internal 10 MHz Reference

A 1:2 vBUC redundant system may be fitted with an internal reference for auto-detection and can switch to an external reference at need. The external reference requires a reference combiner assembly to ensure a continuous reference signal to each vBUC in the system.

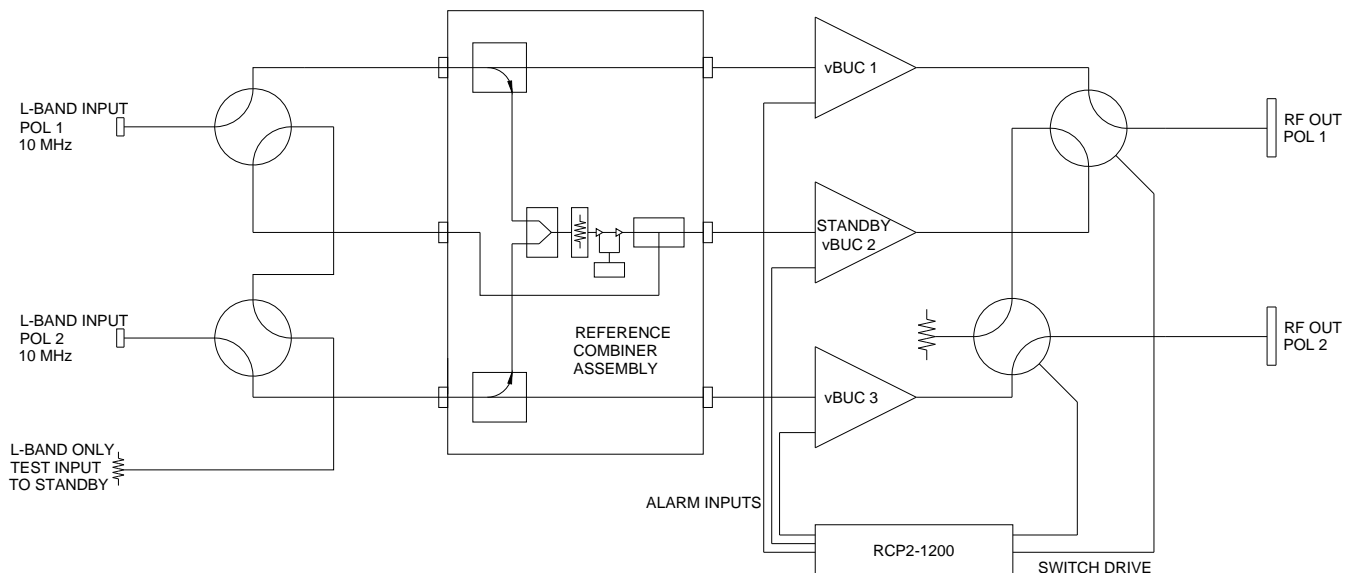

Block Diagram, 1:2 Redundant System, External Reference with Reference Combiner

Redundant Systems (Transmit Only)

Part Number Configuration, 1:1 or 1:2 Transmit Only Systems

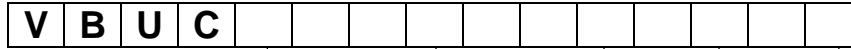

Band
 C - C-Band
 X - X-Band
 K - Ku-Band

Power Level (in Watts)

C-Band
 25, 50, 80¹

X-Band
 10, 25, 35, 80¹

Ku-Band
 10, 16, 25, 40¹

¹ See Drawing Number 208796

Frequency Sub Band

C-Band
 A - 5.85 - 6.425 GHz
 B - 5.85 - 6.725 GHz
 C - 5.75 - 6.670 GHz
 E - 6.425 - 6.725 GHz (Palapa)
 F - 6.725 - 7.025 GHz (Insat)
 G - 5.750 - 6.475 GHz

X-Band
 A - 7.90 - 8.40 GHz

Ku-Band
 A - 14.00 - 14.50 GHz
 B - 13.75 - 14.50 GHz

Input Voltage

A = +48 V
 B¹ = +24 V

¹ Not available with GaN vBUC units

Configuration Modifier

XXX = Standard
 WXX¹ = Waveguide Isolator
 XAX = LNB Power & Reference Port

¹ Standard on GaN vBUC units; Optional with other power levels/bands

System Configuration Options

A¹ = 1:1 w/ Input Switching, Internal Control
 B = 1:1 w/ Input Splitter, Internal Control
 C² = 1:2 w/ Input Switching & RCP2-1200³
 F = 1:1 w/ Input Splitter & RCP2-1100³
 H¹ = 1:1 w/ Input Switching & RCP2-1100³
 J = 1:1 chain redundancy & RCPD-1100³

¹ Not available with units utilizing an external reference.
² 1:2 systems utilizing input switching with an external reference require the use of a reference combiner.
³ Standard Cable Length of 100 ft. (30m) with RCP

Reference Signal

X = Standard External Reference
 R = Internal 10 MHz Reference Oscillator

Input Power Configuration

X = Input Voltage on Circular Connector (Standard)
 A* = AC Power Supply mounted to BUC
 B* = AC Power Supply with DC connectors only
 C* = AC Power Supply with custom-length DC cable
 T* = External IFL Bias Tee

* Available with +48V Input Voltage only

Specifications within this document are subject to change without notice.
 X-band products may be subject to ITAR restrictions and should not be exported from the US without obtaining proper licensing from the appropriate government agencies.