

150W Ku-Band
1:2 Phase Combined
SSPA System

DESCRIPTION

Teledyne Paradise Datacom's family of outdoor packaged, phase combined SSPA systems provide the highest degree of redundancy and system reliability.

1:1 Phase Combined Systems are an economical solution to providing high output power capability with soft-fail redundancy. 1:2 Phase Combined Systems can provide full output power redundancy to mission critical applications which cannot tolerate any decrease in output power capability.

Both 1:1 and 1:2 Phase Combined Systems utilize a signal box through which all RF and L-band input signals are distributed. This ensures that any reference signal is modulated to each amplifier at the same frequency, and that the phase adjustment is optimized.

FEATURES

- Extremely High Power Density:
 - 2.0 kW S-Band;
 - 1.5 kW C-Band;
 - 1.5 kW X-Band;
 - 800 W Ku-Band
- Universal Power Factor Corrected Power Supply
- System Output Power Monitor

OPTIONS

- Hand Held Controller
- Reflected Power Monitor
- L-Band Input operation
- SSPA and Controller Remote Panels
- Auxiliary / Maintenance Output Switch
- Cold Standby Amplifier Operation for Prime Power Savings
- Custom Configurations

1:1 Phase Combined / Redundant System

The 1:1 Fixed Phase Combined Redundant System is a popular system architecture that enables two Solid State Power Amplifiers to operate as a normal 1:1 redundant system or a phase combined system. The basic system topology is very similar to a 1:1 redundant system and is shown in the block diagram. An additional switch is included which allows either amplifier to be individually connected to the antenna or connect both amplifiers to a waveguide combiner.

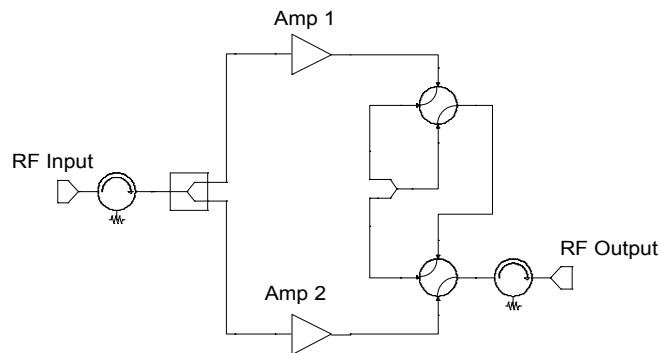

1:1 Phase Combined System Simplified Block Diagram

1:2 Phase Combined / Redundant System

The 1:2 Phase Combined Redundant System is a system architecture that enables Solid State Power Amplifiers to achieve higher output power levels while building in a level of redundancy. The basic system topology is similar to a 1:2 redundant system shown in the block diagram below. Amplifiers #1 and #3 are normally online. The outputs of #1 and #3 are directed by the waveguide switches into a low loss power combiner. In the event of a failure of either on line amplifier, the standby amplifier, #2, can be switched in place of either #1 or #3 and the system maintains **full output power**.

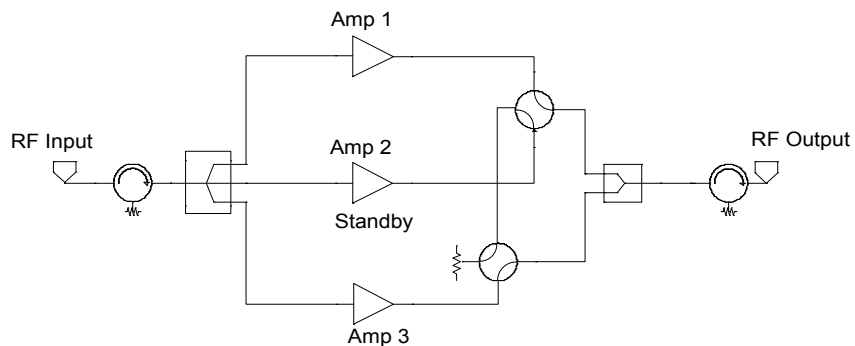

1:2 Phase Combined System Simplified Block Diagram

Outdoor Systems are configured with Teledyne Paradise Datacom's new High Power Outdoor SSPA or popular Compact Outdoor SSPA packages



High Power Outdoor Enclosure Output Power Levels

S-Band: 500W - 1000W
 C-Band: 650W - 800W
 X-Band: 650W - 800W
 Ku-Band: 300W - 500W



Compact Outdoor SSPA Output Power Levels

S-Band: 50W - 500W
 C-Band: 30W - 400W
 X-Band: 25W - 400W
 Ku-Band: 10W - 250W

System Output Power Capacity

Due to the output waveguide and switches, there is always some residual loss in the output of phase combined HPA systems. This results in slightly less than the ideal 3 dB power addition to the output power of a single HPA unit.

On 1:1 phase combined systems, the typical additive output power is 2.70 dB above the output power of a single HPA. On 1:2 phase combined systems, the typical additive output power is 2.50 dB above the output power of a single HPA.

For example, a 125W Ku-Band Compact Outdoor SSPA in a 1:1 phase combined system would have the following output power:

Single Compact Outdoor HPA:	$P_{1dB} = 50.0 \text{ dBm}; P_{sat} = 51.0 \text{ dBm}$
1:1 phase combined system:	$P_{1dB} = 52.7 \text{ dBm}; P_{sat} = 53.7 \text{ dBm}$

L-Band Operation

Teledyne Paradise Datacom Phase Combined HPA Systems can be configured for L-Band Input operation. For optimum RF phase combining over the entire bandwidth of a communication amplifier, the frequency translation part of the system must be separated from the phase combining loop. Therefore, systems with L-Band input are configured with a separate 1:1 system of L-Band Block Up Converters that feed the 1:1 or 1:2 Phase Combined HPA system. If L-Band redundancy is not required, the system can be configured with a single thread L-Band Block Up Converter.

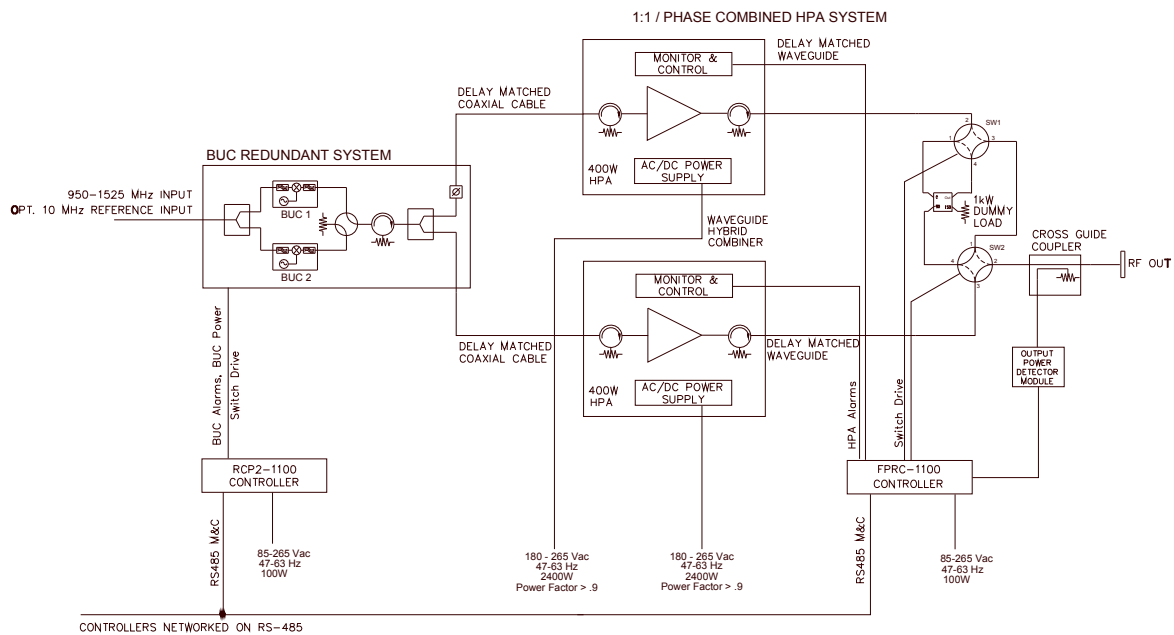

The Block Up Converter system is housed in a weather-proof enclosure (shown below) and controlled by an indoor RCP2-1100 Redundant Controller. The Up Converters can be configured with internal or external reference oscillators. The Teledyne Paradise Datacom ZBUC™ converter architecture allows a converter that is fitted with an internal reference oscillator to automatically detect and switch to an externally applied 10 MHz reference signal.



L-Band Operation

Teledyne Paradise Datacom offers C-, X-, and Ku-Band amplifiers with an integrated L-Band Block Up Converter. The L-Band units utilize Teledyne Paradise Datacom's proprietary zBUC technology. The addition of a zBUC[®] converter to a Compact Outdoor SSPA typically increases the gain by 2-4 dB. The advantages of zBUC technology include:

- zBUC converters can detect and switch to an externally supplied reference.
- Optional internal high stability (10MHz) reference.
- zBUC converters can lock to an externally supplied reference of 5, 10, 20, 25, or 50 MHz without modification.
- zBUC converters can accept a wide range of external reference power (-10 to +5 dBm)
- zBUC converters can accept FSK monitor and control signal via the IFL for complete amplifier remote control.

Available Frequency Plans

Band	Frequency Band	IF Input	LO Frequency	RF Output	Gain Change
C	Standard C-Band	950 - 1525 MHz	4.900 GHz	5.850 - 6.425 GHz	0-4 dB
C	Extended C-Band	950 - 1825 MHz	4.900 GHz	5.850 - 6.725 GHz	0-4 dB
C	Palapa Band	950 - 1250 MHz	5.475 GHz	6.425 - 6.725 GHz	0-4 dB
C	Insat Band	950 - 1250 MHz	5.775 GHz	6.725 - 7.025 GHz	0-4 dB
X	Standard X-Band	950 - 1450 MHz	6.950 GHz	7.900 - 8.400 GHz	0-2 dB
Ku	Standard Ku-Band	950 - 1450 MHz	13.050 GHz	14.00 - 14.50 GHz	0-2 dB
Ku	Extended Ku-Band	950 - 1700 MHz	12.800 GHz	13.75 - 14.50 GHz	0-2 dB
Ku	Sub Ku-Band 2	950 - 1450 MHz	11.800 GHz	12.75 - 13.25 GHz	0-2 dB

Electrical Specifications for Outdoor SSPA with ZBUC converter

PARAMETER	NOTES	LIMITS				UNITS
Gain	Nominal setting	75				dB
Gain Flatness	full band (C-,X-,Ku-bands)	± 2.0				dB
Gain Slope	per 40 MHz (C-,X-,Ku-bands)	± 0.5				dB/40 MHz
Gain Adjusted Range		20				dB
	Typical C-Band Adj. Range	60 - 80				dB
	Typical Ku-Band Adj. Range	57 - 77				dB
Gain Stability	-40 to +60 °C	± 1.5				dB
Phase Noise	Offset frequency from carrier	<u>Absolute max.</u>	<u>C-band (typ.)</u>	<u>X-band (typ.)</u>	<u>Ku-band (typ.)</u>	
	10 Hz	-30	-60	-60	-50	dBc/Hz
	100 Hz	-60	-80	-75	-65	dBc/Hz
	1 KHz	-70	-80	-75	-72	dBc/Hz
	10 KHz	-80	-85	-100	-90	dBc/Hz
	100 KHz	-90	-120	-110	-110	dBc/Hz
	1 MHz	-90	-125	-122	-120	dBc/Hz
Spurious	In-Band Signal Related (C-/Ku-Band) (Extended C-Band)					-50 dBc
	Close to Carrier Spurious (≤ 20 MHz)					-50 dBc
	Local Oscillator					-30 dBm
Noise Figure	At 75 dB gain setting					20 dB
Input VSWR	L-Band					1.5 : 1
Internal Reference Option	Reference accuracy @ 25 °C					± 1 • 10 ⁻⁸
	Reference Stability over Temperature (-40 to +40 °C)					± 1 • 10 ⁻⁹

System Controllers

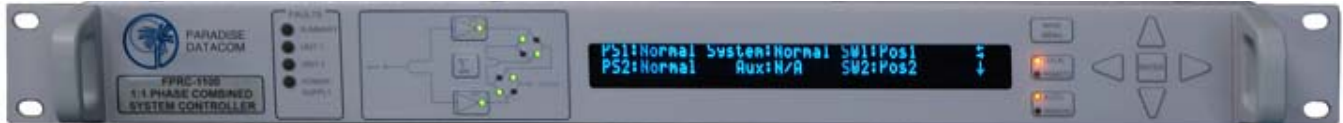

FPRC-1100 1:1 Phase Combined System Controller

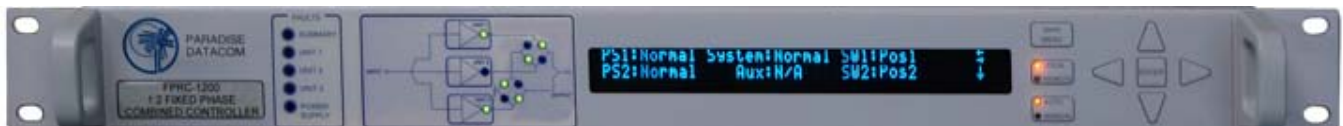

FPRC-1200 1:2 Phase Combined System Controller

The FPRC-1X00 is the heart of the Redundant SSPA System. It provides an extremely user friendly interface for complete monitor and control of the high power amplifiers. The front panel mimic display shows the on-line amplifiers and the switch positions. Fault lights are provided for easy indication of system status.

All FPRC-1X00 monitor and control is available locally at the front panel LCD display, as well as remotely by the RS232 , RS485, or Ethernet interface ports. Audible alarms and a full compliment of parallel I/O signal are available at the rear panel of the FPRC-1X00.

The FPRC-1X00 System Controller allows the Phase Combined System of amplifiers to be controlled as if it were a single SSPA. The FPRC is the single point of interface for either local, front panel, or remote control. System monitor and control capability include gain adjustment, output power monitoring (dBm or Watts), and alarms.

The FPRC-1X00 is a 1RU indoor control unit that contains its own internal redundant components including fully redundant power supplies.

Note: Systems can be configured without the use of a system controller. Consult the factory for operation of phase combined systems without a system controller.

General System Specifications

PARAMETER	NOTES	LIMITS	UNITS
Gain	minimum	70	dB
Gain Flatness	minimum (units with L-Band input)	67	dB
	full band (all except Extended C-Band)	± 1.0	dB
	Extended C-Band units	± 1.5	dB
Gain Slope	per 40 MHz	± 0.3	dB/40 MHz
	per 10 MHz	± 0.2	dB/10 MHz
Gain Variation vs. Temperature	-40 to +60°C	± 1.0	dB
Gain Adjustment	0.1 dB resolution	20	dB
Intermodulation Distortion	3 dB back off relative to P _{1dB}	-25	dBc
AM/PM Conversion	(@ rated P _{1dB})	3.5	°/dB
	(@P _{1dB} - 3 dB)	1.0	°/dB
Spurious Harmonics	(@ rated P _{1dB})	-60	dBc
	(@ rated P _{1dB} - 3 dB) (C-,X-,Ku-bands)	-50	dBc
	(@ rated P _{1dB} - 3 dB) (S-band)	-30	dBc
Input/Output VSWR	Standard band units	1.30:1	
	Extended band units	1.50:1	
Noise Figure	at maximum gain (C-,X-,Ku-bands)	10	dB
	at maximum gain (S-band)	8	dB
Group Delay (per 40 MHz segment)	Linear	0.01	ns/MHz
	Parabolic	0.003	ns/MHz ²
	Ripple	1.0	ns p-p
Transmit Band Noise Output Power Density	TX Band	-75	dBW/4 KHz
	RX Band (C- or Ku-bands)	-150	dBW/4 KHz
	RX Band (X-Band)	-100	dBW/4 KHz
	RX Band (S-Band)	See options	
Receive Band Noise Output Power Density	S-Band, with optional filter	-155	dBW/4 KHz
	S-Band, without optional filter	-95	dBW/4 KHz
Residual AM Noise	0 - 10 KHz	-45	dBc
	10 KHz - 500 KHz	-20 (1.25 + log F)	dBc
	500 KHz - 1 MHz	-80	dBc
Phase Noise	Offset frequency from carrier		
	10 Hz	-90	dBc/Hz
	100 Hz	-100	dBc/Hz
	1 KHz	-110	dBc/Hz
	10 KHz	-120	dBc/Hz
	100 KHz	-125	dBc/Hz
	1 MHz	-130	dBc/Hz

Environmental

Operating Temperature	Ambient	-40 to +60	°C
Relative Humidity	condensing	100	%
Cooling System	integrated	Forced air	

Mechanical

Size, High Power Outdoor	width X length X height	21.0 X 27.95 X 13.5	inches
		533 X 710 X 343	mm
Size, Compact Outdoor	width X length X height	10.0 X 19.5 X 6.50	inches
		254 X 495 X 165	mm
Weight, High Power Outdoor		100 (45.5)	lbs.(kg)
Weight, Compact Outdoor	Base unit (< 200W S/C-bands; < 100W Ku)	36 (16.4) ± 3%	lbs.(kg)
	Base unit (≥ 200W S/C-bands; ≥ 100W Ku)	44 (20.0) ± 3%	lbs.(kg)
	Base unit (< 200W X-Band)	46.7 (21.1) ± 3%	lbs.(kg)
	Base unit (≥ 200W X-Band)	54.9 (25.0) ± 3%	lbs.(kg)
	With Internal zBUC	+1.7 (0.8)	lbs.(kg)
Finish		Paint	White; powder coat

Part Number Configuration, High Power Outdoor SSPA System

HPA **C 2 8 0 0 A H M G S X X G**

Band	
S-Band	S
C-Band	C
X-Band	X
Ku-Band	K

Generation	
Second	2

Power Level (Watts)	
S-Band	600, 800, 1000 (10K)
C-Band	650, 800
X-Band	650, 800
Ku-Band	300, 400, 500

Frequency Sub Band	
S-Band	
A	2.02 to 2.12 GHz
B	2.20 to 2.30 GHz
G	1.75 to 2.12 GHz
C-Band	
A ¹	5.850 to 6.425 GHz
B ¹	5.850 to 6.725 GHz
C	5.750 to 6.670 GHz
D ¹	6.425 to 7.025 GHz
H	5.715 to 5.790 GHz
L	4.400 to 5.000 GHz
X-Band	
A ¹	7.90 to 8.40 GHz
D	7.70 to 8.40 GHz
F	7.10 to 7.40 GHz
Ku-Band	
A ¹	14.00 to 14.50 GHz
B ¹	13.75 to 14.50 GHz
C ¹	14.50 to 14.70 GHz
D ¹	15.10 to 15.40 GHz
F ¹	12.75 to 13.25 GHz
G ¹	14.75 to 15.25 GHz

GaN Device Designator	
G	GaN Technology

Configuration Modifier 3	
X	None (Standard)

Configuration Modifier 2	
X	Standard
R ¹	Receive Band Reject Filter
V	Reflected Power Monitor
Y ¹	R + V (see above)

¹ S-Band and X-Band units only

Configuration Modifier 1	
X	Standard
S	Input Sample Port

System Configuration	
E	1:2 FPC System, Input Splitter, FPRC-1200 ¹
G	1:1 FPC System, Input Splitter, FPRC-1100 ¹
J	1:2 FPC System, Input Splitter, Internal control

¹ Standard cable length of 100 ft. (30m) with FPRC

Block Up Converter	
M	Internal Reference BUC
P	External Reference BUC
X	No BUC

Package	
H	High Power Outdoor SSPA

¹ Available with optional BUC

Example - A 1:1 Fixed Phase Combined 800W System utilizing two (2) GaN C-Band High Power Outdoor SSPAs with optional input sample ports and optional internal reference block up converters is part number: **HPAC2800AHMGSXXG**.

Part Number Configuration, GaAs Compact Outdoor Systems

HPA **K 2 0 7 0 A C M G X X X**

Band	
S-Band	S
C-Band	C
X-Band	X
Ku-Band	K

Generation	
Second	2

Power Level (Watts)	
S-Band	050, 100, 200, 300
C-Band	030, 040, 050, 075, 100, 140, 200, 250, 300
X-Band	025, 030, 060, 075, 100, 140, 200, 250
Ku-Band	010, 020, 025, 035, 040, 050, 070, 100, 125

Frequency Sub Band	
S-Band	
A	2.02 to 2.12 GHz
B	2.20 to 2.30 GHz
C-Band	
A ¹	5.850 to 6.425 GHz
B ¹	5.850 to 6.725 GHz
C	5.750 to 6.670 GHz
E ¹	6.425 to 6.725 GHz
F ¹	6.725 to 7.025 GHz
G	5.750 to 6.475 GHz
H	5.715 to 5.790 GHz
J	5.740 to 6.650 GHz
V ^{1,2}	5.850 to 6.725 GHz
X-Band	
A ¹	7.90 to 8.40 GHz
B	7.50 to 8.50 GHz
D	7.70 to 8.40 GHz
E	7.75 to 8.50 GHz
Ku-Band	
A ¹	14.00 to 14.50 GHz
B ¹	13.75 to 14.50 GHz

Configuration Modifier 3	
X	None (Standard)
A	Side-mount AC Input, Location 'A'
D	48 VDC Input
F	Side-mount 48 VDC Input, Location 'A'

Configuration Modifier 2	
X	Standard
M	MS-Connector Covers
R ¹	Receive Band Reject Filter
S	M + R (see above)

¹ S-Band and X-Band units only

Configuration Modifier 1	
X	Standard
K	110 VAC Input

¹ Available in C- and X-Band models ≥ 140W and Ku-Band models ≥ 100W

System Configuration	
E	1:2 FPC System, Input Splitter, FPRC-1200 ¹
G	1:1 FPC System, Input Splitter, FPRC-1100 ¹
J	1:2 FPC System, Input Splitter, Internal control

¹ Standard cable length of 100 ft. (30m) with FPRC unit.

Block Up Converter	
M	Internal Reference BUC
P	External Reference BUC
X	No BUC

Package	
C	Compact Outdoor SSPA

¹ Available with optional BUC
² With 1.3:1 VSWR

Example - A 1:1 phase combined standard frequency 70W Ku-Band Compact Outdoor SSPA system with input splitter and an internal reference BUC, and using a FPRC-1100 system controller, is part number: **HPAK2070ACMGXXX**.

Part Number Configuration, GaN Compact Outdoor Systems

HPA **X 2 3 0 0 A C M J X X X G**

Band	
S-Band	S
C-Band	C
X-Band	X
Ku-Band	K

Generation	
Second	2

Power Level (Watts)	
S-Band	050, 100, 200, 300, 400, 500
C-Band	300, 400
X-Band	300, 400
Ku-Band	100, 150, 200, 250
Ka-Band	040, 100

Frequency Sub Band	
S-Band	
A	2.02 to 2.12 GHz
B	2.20 to 2.30 GHz
G	1.75 to 2.12 GHz
C-Band	
A ¹	5.850 to 6.425 GHz
B ¹	5.850 to 6.725 GHz
C	5.750 to 6.670 GHz
D ¹	6.425 to 7.025 GHz
H	5.715 to 5.790 GHz
L	4.400 to 5.000 GHz
X-Band	
A ¹	7.90 to 8.40 GHz
D	7.70 to 8.40 GHz
F	7.10 to 7.40 GHz
Ku-Band	
A ¹	14.00 to 14.50 GHz
B ¹	13.75 to 14.50 GHz
F ¹	12.75 to 13.25 GHz
G ¹	14.75 to 15.25 GHz

¹ Available with optional BUC

GaN Device Designator	
G	GaN Technology

Configuration Modifier 3	
X	None (Standard)
A	Side-mount AC Input, Location 'A'

Configuration Modifier 2	
X	Standard
M	MS-Connector Covers
R ¹	Receive Band Reject Filter
S	M + R (see above)

¹ S-Band and X-Band units only

Configuration Modifier 1	
X	Standard

System Configuration	
E	1:2 FPC System, Input Splitter, FPRC-1200 ¹
G	1:1 FPC System, Input Splitter, FPRC-1100 ¹
J	1:2 FPC System, Input Splitter, Internal control

¹ Standard cable length of 100 ft. (30m) with FPRC unit.

Block Up Converter	
M	Internal Reference BUC
P	External Reference BUC
X	No BUC

Package	
C	Compact Outdoor SSPA

Example - A 1:1 phase combined standard frequency 300W X-Band GaN Compact Outdoor SSPA system with input splitter and internal control with an external reference BUC is part number: **HPAX2300ACMJXXG**.

Use and Disclosure of Data

The information contained herein is classified as EAR99 under the U.S. Export Administration Regulations. Export, re-export or diversion contrary to U.S. law is prohibited.

Specifications are subject to change without notice.